

HJBMX 40 T6 0,18kW Zone 1: FAN (Ex h IIB+H2 T4 Gb) + MOTOR (Ex db IIC T5 Gb) (268413106XD)

GENERAL DATA



ATEX SQUARE WALL PLATE FAN WITH VARIABLE PITCH BLADES

MANUFACTURING FEATURES

- Square plate made of inox steel AISI 304.
- Variable pitch angle PAGAS (PA6 GF30 AS) impeller.
- Supplied with galvanized motor support and protection guard according to the ROHS 2002/95/EC Directive (Restriction of the Use of Certain Hazardous Substances in Electrical and Electronic Equipments).
- ATEX standard asynchronous motor. ATEX certified: II2G Ex d, Standard voltages 230V 50Hz for single phase motors, 230/400V 50Hz for three phase motors. IP55 protection.

APPLICATIONS

Designed for wall assembly, they are suitable for:

- Air renewal in buildings and industries.
- Smoke extraction (max. 60°C).
- General ventilation in closed environments classified as ATEX.
- Working temperature: ambient from -20°C to 60°C

UNDER REQUEST

- 60Hz fans and special voltages.
- Stainless protection grid.

ORGANISM: L.O.M.
CERTIFICAT N°: LOM 17.755X-C

In compliance with the Directive 2014/34/UE

PERFORMANCE CURVE

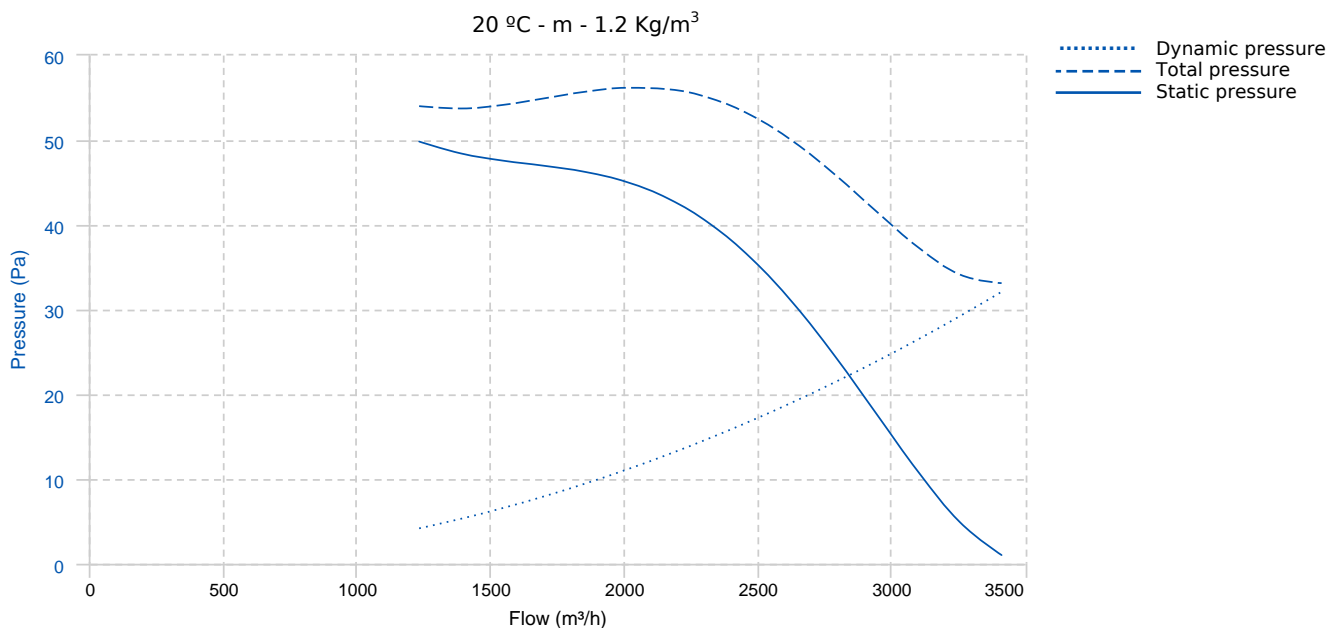

TECHNICAL DATA

Fan							
RPM	908	Approx. weight	9 kg	Max. Flow	3420 m ³ /h		
Motor							
Power	0,18 kW	RPM	908	I max. (400V)	0,8 A	Size	71
Efficiency (%)	45.91 %	FP	0.7				

DIMENSIONS

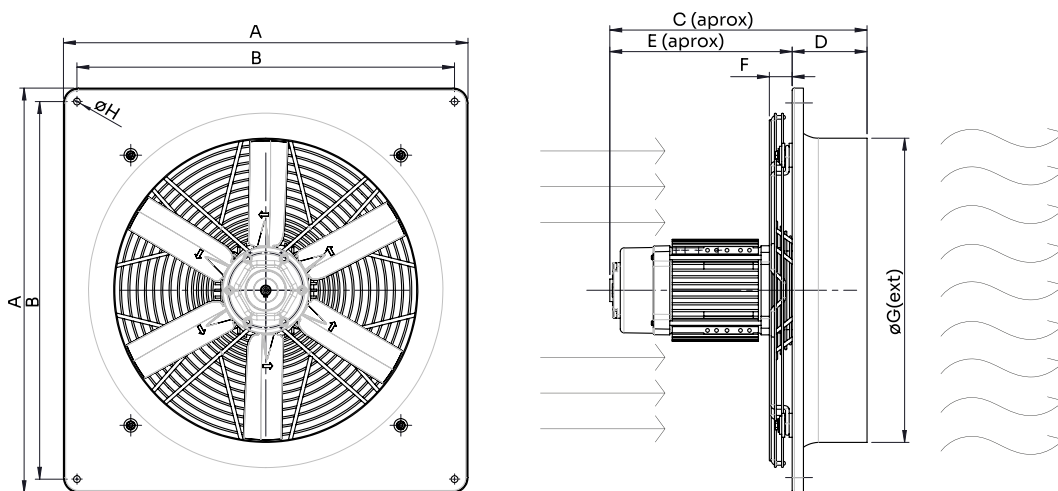

Dimensions (mm)									
A	540	B	504	C	343.5	D	100	E	243.5
F	30.5	G	406	H	9				

WIRING DIAGRAM

230V

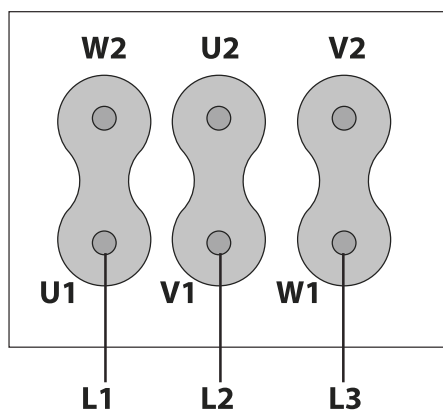

400V

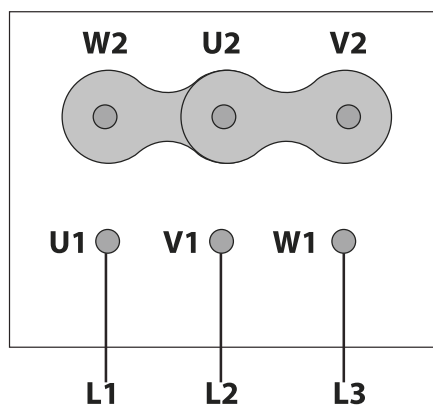

ACCESSORIES



**Outlet protection guard for axial fans
RP0 40**
REF: 980000040



**ATEX SWITCH
INT 16 ATEX**
REF: 510200016X



**FREQUENCY SPEED CONTROLLER
SFC 230 I 2,5A ***
REF: SFC230I003



**FREQUENCY SPEED CONTROLLER
SFC 400 III 1,2A ***
REF: SFC400III1

SPARE PARTS

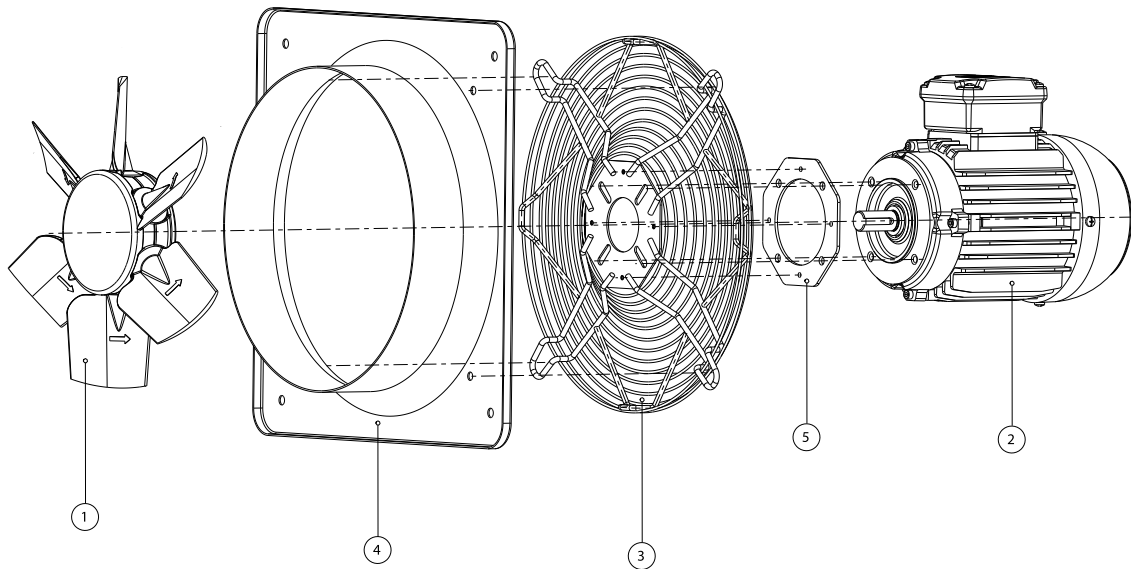

	Code	Model	Qty
2	721601219M050	MOTOR 0,18KW T6 B14	x1